

LITHIUM-ION

FE4C50

5,000 lbs. Capacity
Four Wheel Lithium-Iron Cushion



Capacity
5,000lb

Lithium-ion
Battery

High
Performance

Robust
Design

CAN-bus
CAN-bus

High
Efficiency

Easy
Maintenance

Ergonomic
Design

Why choose between price and quality **WHEN YOU CAN HAVE BOTH!**

HIGHLIGHTS

- ▶ Powerful high quality AC drive system
- ▶ Infinitely variable hydraulic control speeds
- ▶ On-demand fully hydrostatic power steering (FHPS)
- ▶ 4-Way proportional hydraulic control valve
- ▶ Side-shift
- ▶ Multi-function LED Display
- ▶ Deluxe suspension seat
- ▶ Tilt steering column
- ▶ Intelligent Monitoring System (IMS) display indicators
- ▶ CAN-bus communications system
- ▶ On-board self-diagnostics
- ▶ Wireless 4G battery monitoring
- ▶ Operator presence sensing system
- ▶ Safety Blue light, LED rear work light, headlights, and strobe
- ▶ Rear grab bar with horn
- ▶ Tilt cylinder boots
- ▶ All-around front wheel drive
- ▶ Side extraction battery



FE4C50

5,000 lbs. Capacity

Four Wheel Lithium-Iron Cushion

The FE4C50 cushion tire forklifts are highly efficient, durable Lithium-iron forklifts. They are designed for indoor warehouse applications and other applications with hard smooth floors. The mast system, front/rear axles and chassis are engineered to be tough like an Internal Combustion forklift, but with all the advantages of Lithium-iron. AC drive technology is used to achieve high performance with low operating and maintenance costs. Greatly increase your work productivity with these quiet, very low maintenance, ultra-smooth, lithium-iron forklifts.

PRODUCTIVE. SOLID. SMART.



COMPACT. HIGH PERFORMANCE. EFFICIENT.



Compact design allows for a 360 degree zero-turning radius, enabling the truck to operate in confined spaces.

Operator can select different performance modes on color LCD display to meet different applications. Multi-function LCD display: speed, steer angle, travel direction, battery discharge indicator, hour meter and working mode.

Large 80-volt Lithium-iron battery and regenerative braking system significantly increase operating hours per charge.

High-power oil pump motor and large displacement gear pump increase lifting and lowering speed, and improve working efficiency.



ERGONOMIC. GREAT VISIBILITY.



The large, ergonomic cab and user-friendly design ensures operator comfort throughout the entire work shift. Low entrance height provides operator easy and safe access.

Deluxe suspension, fully adjustable seat reduces vibration to the driver to effectively reduce driver fatigue for all sizes of operators.



On-Demand Fully Hydrostatic Power Steering (FHPS) guarantees smooth steering, preventing over-run and kick-back. Spinner knob allows easier one-handed steering.



Mast layout is optimized for a wide view and clear visibility while operating.

SAFETY. RELIABILITY.



Heavy-duty steel chassis, axles, mast and overhead guard deliver high strength and stability for high lifting heights and heavy loads.



Intelligent buffering effectively protects the ground and cargo from damage while forks descend to the ground.



Safety belt restraint warning system is standard and keeps operator safe and secure while operating the truck.



Operator Presence System (OPS) — When operator is not in seat, the hydraulic lift and tilt controls automatically lock out and traveling is disabled.



Electronic components are all high-quality, well-known brands and ensure optimum performance, smooth control and reliability.



Rear grab bar with horn provides easy horn operation while traveling in reverse and keeps the operator's hand safely within the truck at all times.



Equipped with LED lamps: Rear work lights, headlights, strobe and safety blue light.



Automatic decelerating while turning, improves safety, stability and operator comfort, while preventing product damage.



Driving Speed

EASY MAINTENANCE



Battery compartment is equipped with a side battery removal assembly for easy removal and replacement.



Removable side panels enable easy service and maintenance, while providing excellent water and dust protection.



Tilt cylinder boots protect tilt cylinder and oil seals from the environment, prolonging cylinder life.



Brake fluid can be added very conveniently by opening the shield cover and oil tank cover.



Easily check truck's condition and troubleshoot with InMotion controller and CAN-bus technology.



Wireless 4G battery monitoring allows for remote battery programming and troubleshooting.

HIGH EFFICIENCY AND SAFE LITHIUM-ION POWER

NOBLELIFT uses Lithium-Iron Phosphate batteries, the longest lasting and safest lithium-ion battery available. Our lithium-iron batteries are equipped with a Battery Management System (BMS), thermal management system, and an automotive-grade DC high-voltage control system. BMS manages charging and discharging data to ensure safety throughout its life cycle.

FE4C50 forklifts have a 5 year or 10,000 hours warranty on the lithium-Iron battery.



ADVANTAGES OF LITHIUM-ION POWER



Fast-charging maintenance-free Lithium-Iron battery is fully charged in 2 hours. Battery can be opportunity charged during user breaks and during shift changes which allows the truck to run continuously through multi-shift operations. No battery changes are necessary.

LITHIUM BATTERY ADVANTAGES

Lead-Acid Battery		Lithium Battery
Lower fleet availability - Work is interrupted because battery needs to be fully charged before next use	Productivity - Memory Effect 	100% Fleet availability - Opportunity charging allows battery to be charged in between use
Periodic battery replacement	Service Life 	Batteries last 3 times longer and do not need to be replaced
Outsourced or in-house maintenance personnel required	Ongoing Maintenance 	No maintenance cost
8-10 Hours - 2 or more batteries per lift truck	Charge Duration 	2 Hours - 1 Battery per lift truck
Build an expensive battery room with ventilation	Battery Room 	No battery room needed
Releases hydrogen while charging - Can result in explosion - Acid burns can happen during maintenance	Dangerous Substances 	No dangerous substances
Power loss	Power Savings 	No power loss - Reduces energy consumption by 35%

TOTAL COST OF OWNERSHIP

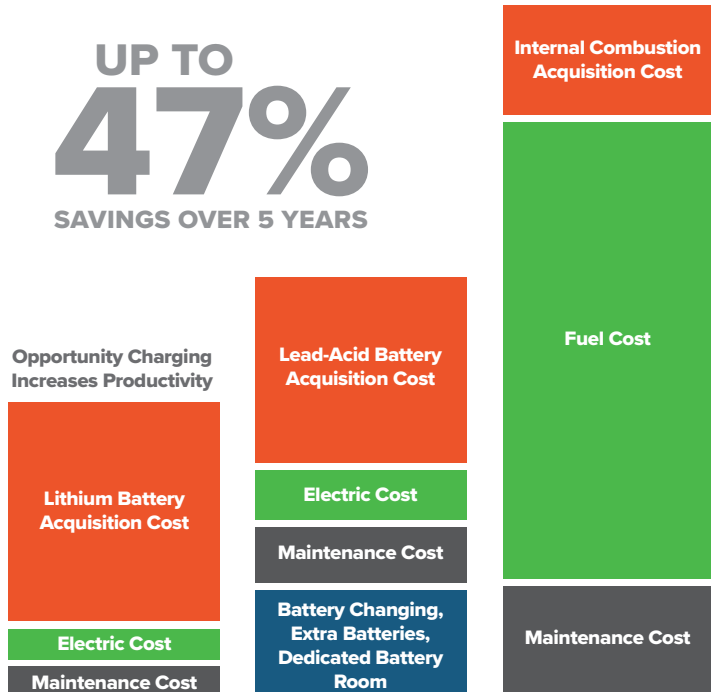

Opportunity Charging Increases Productivity

Lead-Acid Battery Acquisition Cost

Lithium Battery Acquisition Cost

Electric Cost

Maintenance Cost

Battery Changing, Extra Batteries, Dedicated Battery Room

Electric Cost

Maintenance Cost

Fuel Cost

Maintenance Cost

REMA/
Anderson
plug-in

Mast Table FE4C50

Designation	Lift height h3 (in)	Free lift height h2 (in)	Closed mast height h1 (in)	Extended mast height h4 (in)	Tilt forward/backward a/b (°)	Capacity table (lb) C=24in without sideshift single cushion tires
						FE4C50
Two-stage ZT	98.4	5.3	71.7	136.9	6 / 8	5,000
	118.1	5.3	81.5	156.5	6 / 8	5,000
	129.9	5.3	87.4	168.3	6 / 8	5,000
	137.8	5.3	91.3	176.2	6 / 8	5,000
	145.7	5.3	95.3	184.1	6 / 8	5,000
	157.5	5.3	103.1	195.9	6 / 6	5,000
	169.3	5.3	109.1	207.7	6 / 6	5,000
	177.2	5.3	113.0	215.6	6 / 6	4,910
Two-stage ZZ	196.9	5.3	122.8	235.3	6 / 6	4,580
	98.4	34.7	71.7	136.9	6 / 8	5,000
	118.1	44.5	81.5	156.5	6 / 8	5,000
	129.9	50.4	87.4	168.3	6 / 8	5,000
	137.8	54.4	91.3	176.2	6 / 8	5,000
	145.7	58.3	95.3	184.1	6 / 6	5,000
Three-stage DZ	157.5	66.2	103.1	195.9	6 / 6	5,000
	157.5	36.5	69.1	195.0	6 / 6	5,000
	171.3	41.5	74.0	208.7	6 / 6	5,000
	177.2	43.4	78.9	214.6	6 / 6	4,890
	189.0	47.4	80.9	226.5	6 / 6	4,740
	196.9	50.3	84.8	234.3	6 / 6	4,540
	216.5	57.2	87.8	254.0	6 / 6	4,050
Four-stage DZ	236.2	65.1	94.7	273.7	6 / 6	3,000
	240.2	46.0	84.1	276.6	6 / 3	2,640
	259.8	50.9	89.0	296.3	6 / 3	1,980
	275.6	57.2	95.3	312.0	6 / 3	1,540

Free lifting height without stop shelf +11.9 in.

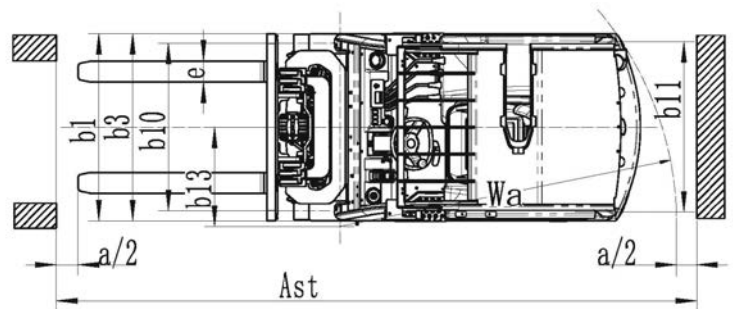
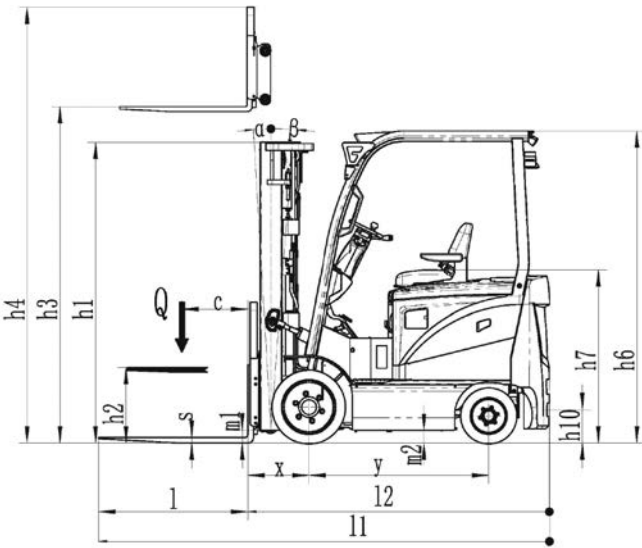

Identification			
1.1	Manufacturer		NOBLELIFT
1.2	Model		FE4C50
1.3	Drive (electric – battery or mains, diesel, petrol, gas, manual)		Electric
1.4	Type of operation (hand, pedestrian, standing, seated, order picker)		Seated forklift
1.5	Load capacity / rated load	Q (lb)	5,000
1.6	Load center distance	c (in)	24
1.8	Load distance, center of drive axle to fork	x (in)	17.3
1.9	Wheel base	y (in)	51
Weights			
2.1	Service weight including battery (see line 6.5)	lb	9,405
2.2	Axle loading, laden front / rear	lb	12,705 / 2,200
2.3	Axle loading, unladen front / rear	lb	3,465 / 5,940
Wheels, Chassis			
3.1	Tires (solid rubber, superelastic, pneumatic, polyurethane)		Solid rubber
3.2	Tire size, front		21x7-15
3.3	Tire size, rear		16x6-10.5
3.5	Wheels, number front / rear (x = driven wheels)		2x / 2
3.6	Track width, front	b ₁₀ (in)	37.7
3.7	Track width, rear	b ₁₁ (in)	36.3
Basic Dimensions			
4.1	Mast / fork carriage tilt forward / backward	a/b (°)	6 / 8
4.2	Lowered mast height	h ₁ (in)	85.4
4.3	Free lift	h ₂ (in)	4.7
4.4	Lift height	h ₃ (in)	118.1
4.5	Extended mast height	h ₄ (in)	156.6
4.7	Overhead load guard height	h ₆ (in)	88.6
4.8	Seat height / standing height	h ₇ (in)	49.2
4.12	Coupling height	h ₁₀ (in)	11.6
4.19	Overall length	l ₁ (in)	127
4.20	Length to face of forks	l ₂ (in)	84.8
4.21	Overall width	bl (in)	42.5
4.22	Fork dimensions	s/e/l (in)	1.6 / 4.7 / 42.1
4.24	Fork carriage width	b ₃ (in)	40.9
4.31	Ground clearance, laden, under mast	m ₁ (in)	4.3
4.32	Ground clearance, center of wheelbase	m ₂ (in)	4.7
4.33	Aisle width for pallets 1000 x 1200 crossways	Ast (in)	141.3
4.34	Aisle width for pallets 800 x 1200 lengthways	Ast (in)	149.2
4.35	Turning radius	Wa (in)	76.8
Performance Data			
5.1	Travel speed, laden / unladen	mph	9.3 / 9.3
5.2	Lift speed, laden / unladen	fpm	67 / 79
5.3	Lowering speed, laden / unladen	fpm	<118
5.5	Drawbar pull, laden / unladen S2 60 min	blf	7,260 / 5,060
5.7	Max. Gradient performance, laden / unladen S2 5 min	%	15 / 20
5.10	Service brake		Hydraulic
E-Motor			
6.1	Drive motor rating S2 60 min	HP	16.1
6.2	Lift motor rating at S3 15%	HP	21.4
6.3	Battery standard		Lithium-iron phosphate
6.4	Battery voltage, nominal capacity K5	V/Ah	80 / 412
6.5	Battery weight	lb	704
	Battery dimensions l/w/h	in	38.6 / 24.8 / 23.8
	Charger standard	V/A	80 / 200 208-240V or 480V 3-phase
	Operating Temperature	°F	-4 to 131
Other Details			
8.1	Type of drive control		AC
8.2	Operating pressure for attachments	psi	2,538
8.3	Oil volume for attachments	gmp	570
8.4	Sound level at driver's ear according to EN 12 053	dB(A)	73

A GLOBAL LEADER

NOBLELIFT is a global leader in Lithium-ion Technology. We manufacture more than 200 categories and around 30 series of each product. Our products are designed to meet different application demands and are well accepted by our customers in more than 100 countries and regions in Europe, America, Asia, Africa and more.

Products include: sit-down forklifts, rough terrain forklifts, narrow aisle forklifts, walkie-stackers, order pickers, electric pallet trucks, scissor lifts, tuggers, scrubbers, lift tables, manual pallet jacks and more.



FORKLIFTS



NARROW AISLE



STACKERS



POWERED PALLET TRUCKS



SCISSOR LIFTS



TUGGERS



SCRUBBERS

NOBLELIFT

AUTHORIZED DEALER